

Operation & Maintenance

Well Water Treatment System



1249 W. Airport Blvd. Sanford, Fl. 32773

www.discountwatersupply.com

This is a general guide for most systems that use the chlorination/dechlorination and ion-exchange softening method of water treatment.

407-323-9010

1-877-753-4140

Weekly

- Measure chlorine residual at filter inlet. Adjust for 1.0 to 3.0 mg/L.
- Check that clocks are on correct time of day.
- Check salt level. Add salt when water is visible. Break up any solidified salt as needed.
- Add Res-up to softener as needed.
- Check chlorine level. Maintain a mixture of 1 gallon chlorine to 1 barrel (30 gallons) of water. Extreme conditions may require a stronger solution.
- Check that drains are unobstructed.
- Check all associated equipment for normal operation.

Monthly

- Purge drain on retention tank until water runs clear.
- Drain and flush tank if heavy deposits are observed.
- Manually turn filter and softener control knobs through their cycles. If the knobs are hard to rotate, replace the valve seals.
- Inspect system for leaks.
- Measure chlorine residual at spigot near system outlet. Any residual detected means chlorine has passed through filter. Replace the filter media.
- Check well pump for leaks and unusual sounds. Repair promptly.
- Analyze treated water to monitor system efficiency.

Annually

- Empty and clean salt and chlorine tanks.
- Inspect chlorine pump and system. Clean as required. Replace worn parts as needed.
- Disassemble and clean softener brine screen, brine valve and injector. See manual for details.
- Disassemble and clean valve assemblies in the filter and the softener. Replace seals and pistons as needed. See manual for details.
- Drain and check air pressure in the pressure tank. Adjust to 2 p.s.i. below pump cut-on pressure, or as recommended by manufacturer.
- Analyze source water and note changes in quality.

SEE DIAGRAM ON BACK

NOTES

Copyright 2006

Discount Water Supply Inc.

All rights reserved. 8-24-06

WELL WATER SYSTEM DIAGRAM

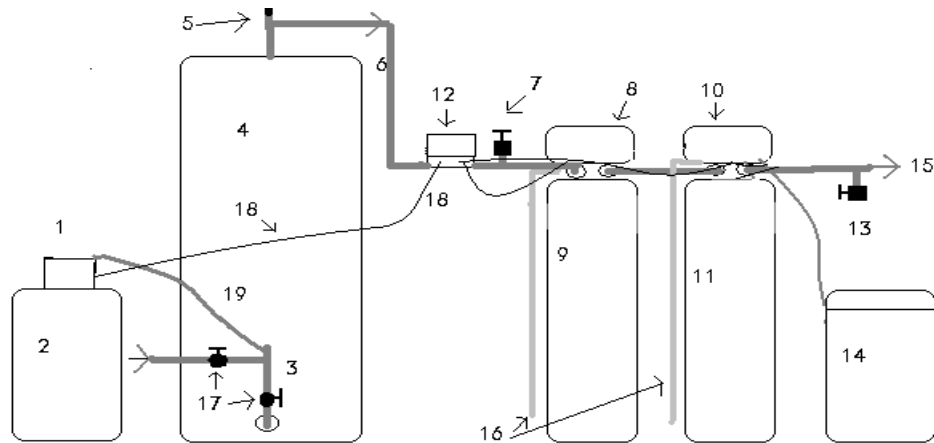

CAUTION: FOLLOW ALL APPLICABLE BUILDING, PLUMBING AND ELECTRICAL CODES AND ORDINANCES.

- 1 THE CHLORINE PUMP MOVES CHLORINE SOLUTION FROM BARREL TO INJECTOR AT POINT WHERE WATER FROM THE WELL ENTERS TO RETENTION TANK
 - 2 CHLORINE SOLUTION BARREL. USUALLY 35 GALLONS. TYPICAL MIXTURE IS 1 OR MORE GALLONS OF CHLORINE TO BARREL OF WATER. USE LIUID POOL CHLORINE, 10% SODIUM HYPOCHLORITE.
 - 3 WATER FROM THE WELL ENTERS THE BOTTOM OF THE RETENTION TANK
 - 4 RETENTION TANK. CHLORINE REACTS WITH WATER HERE. CHLORINE KILLS BACTERIA, OXIDIZES SULFUR AND IRON. OXIDIZED SOLIDS SETTLE TO THE BOTTOM. WATER FLOWS OUT THROUGH THE TOP FITTING THROUGH PIPE TO FILTER TANK. SETTLED SOLIDS SHOULD BE FLUSHED OUT THROUGH DRAIN PERIODICALLY, AT LEAST MONTHLY, THROUGH THE DRAIN AT THE BOTTOM. (DRAIN NOT SHOWN)
 - 5 VACUUM RELIEF VALVE, ALLOWS AIR TO ENTER SYSTEM IN EVENT OF TANKS BEING DRAINED. PREVENTS COLLAPSE OF TANK LINERS. REQUIRED BY WARRANTY.
 - 6 PIPE ASSEMBLY CARRIES WATER FROM RETENTION TANK TO FILTER TANK.
 - 7 SPIGOT FOR TESTING CHLORINE CONTENT OF WATER, SHOULD BE 1 TO 3 PARTS PER MILLION. USE A SWIMMING POOL TEST KIT.
 - 8 AUTOMATIC BACKWASH CONTROL, BACKWASHES FILTER TO KEEP CARBON CLEAN.
 - 9 TANK CONTAINING ACTIVATED CARBON. PURPOSE, TO REMOVE CHLORINE AND SOLID PARTICLES FROM WATER. CARBON SHOULD BE REPLACED ANNUALLY OR AS CONDITIONS REQUIRE. TANK IS HALF FULL TO ALLOW ROOM FOR MEDIA TO LIFT DURING BACKWASH.
 - 10 SOFTENER BACKWASH CONTROL. ONE END OF SALT TANK HOSE CONNECTION ATTACHES TO BRINE VALVE FITTING.
 - 11 SOFTENER TANK, CONTAINS ION-EXCHANGE RESIN. TANK IS HALF FULL TO ALLOW ROOM FOR MEDIA TO LIFT DURING BACKWASH. SOFTENER RESIN DOES NOT USUALLY WEAR OUT. IF RESIN BED IS FOULED WITH IRON OR SULFUR, CLEAN WITH RES-UP OR SIMILAR RESIN CLEANER.
 - 12 FLOW SWITCH. WATER FLOWS THROUGH , TURNING ON ELECTRICAL CIRCUIT WHICH ACTIVATES THE CHLORINE PUMP. ONE OUTLET IS ENERGIZED BY CIRCUIT. PLUG CHLORINE PUMP INTO THAT OUTLET. OTHER OUTLET(S) CONSTANTLY ENERGIZED FOR PLUGGING IN FILTER AND SOFTENER CONTROLLERS. PLUG THE FLOW SWITCH POWER CORD ONLY INTO AN APPROVED 120 VOLT OUTLET.
- CONSULT LICENSED ELECTRICIAN IF ANY ELECTRICAL WORK IS NEEDED.**
- 13 SPIGOT FOR TESTING FINISHED WATER.
 - 14 SALT BARREL. CONTAINS SOFTENER SALT. USUALLY HAS SAFETY FLOAT TO PREVENT OVERFLOW OF WATER. UPON STARTUP, PUT ABOUT 4" WATER IN AND ADD SALT. EMPTY AND CLEAN BARREL AT LEAST ANNUALLY. ADD WATER AS ABOVE WHEN PUTTING BARREL BACK IN SERVICE.
 - 15 PIPELINE TO CARRY FINISHED WATER TO HOME.
 - 16 DRAINS FOR BACKWASH WATER. USUALLY 1/2" PIPE THREAD CONNECTION AT SOFTENER AND FILTER CONTROLLER. ROUTE PIPES TO SAFE AREA FOR DRAIN WATER. DRAIN WATER FROM THE SOFTENER CONTAINS SALT. IF ROUTED OUTSIDE, IT MAY KILL GRASS OR PLANTS. FILTER DRAINWATER MAY CONTAIN RUST DEPOSITS. USE CHECK VALVES OR BACKFLOW PREVENTERS TO PROTECT DRINKING WATER FROM POSSIBLE CONTAMINATION.
 - 17 GATES VALVES, ISOLATE CHLORINE INJECTOR FOR SERVICE AND WATER SHUT-OFF.
 - 18 POWER CORDS, PLUGGED INTO FLOW SWITCH.

CAUTION

NEVER CONNECT DRAIN DIRECTLY TO WASTE OR SEWER PIPE WITHOUT PROPER PROVISIONS FOR BACKFLOW PREVENTION. INSTALL BACKFLOW PREVENTION DEVICE BETWEEN SOURCE WATER AND TREATMENT SYSTEM. FOLLOW ALL LOCAL PLUMBING CODES. CONSULT A LICENSED PLUMBER.